

Note:

- . Values stated in Specifications are for bracket only, in compliance with a good anchoring system and wall structure.
- . All items finish hot dip galvanized
- . All fasteners M10 Grade 8.8 HDG.
- . All Grade 8.8 fasteners to be torqued 45Nm (±10%)
- . Weight of bracket incl. fasteners = 26.243kg

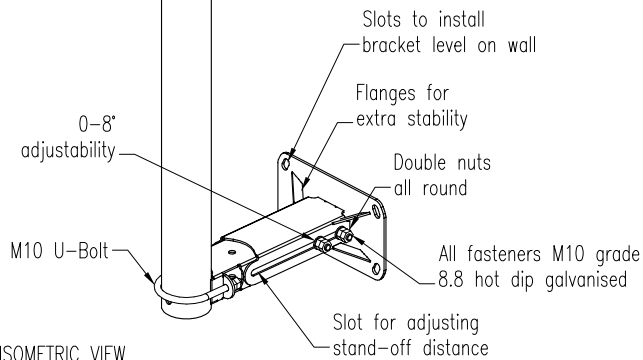

ISOMETRIC VIEW

Specifications

Design Criteria

SANS 10160(Wind load) | SANS 10162(Structural)

Safe work load

Dead weight	A	100kg
Lateral loading (Front)	B	300kg
Lateral loading (Side) Ø76 tower leg	C	100kg
Lateral loading (Back)	D	300kg
Torque (On tubing)	E	1200Nm

Parts list

Qty/Description	Part number
2x Wall to pole bracket	GR112/201/01-00
1x 3m Ø76 Pole	RTU167
2x Slider section	GR112/151/01-00

Fastners list

Description	Qty
M10X30 HDG Setscrew	8
M10 Hex nut	24
M10 Flat washer	20
M10 X Ø76 U-Bolt	2

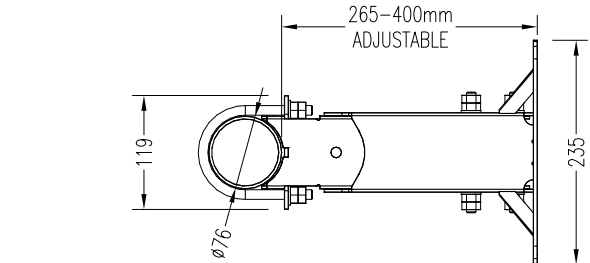
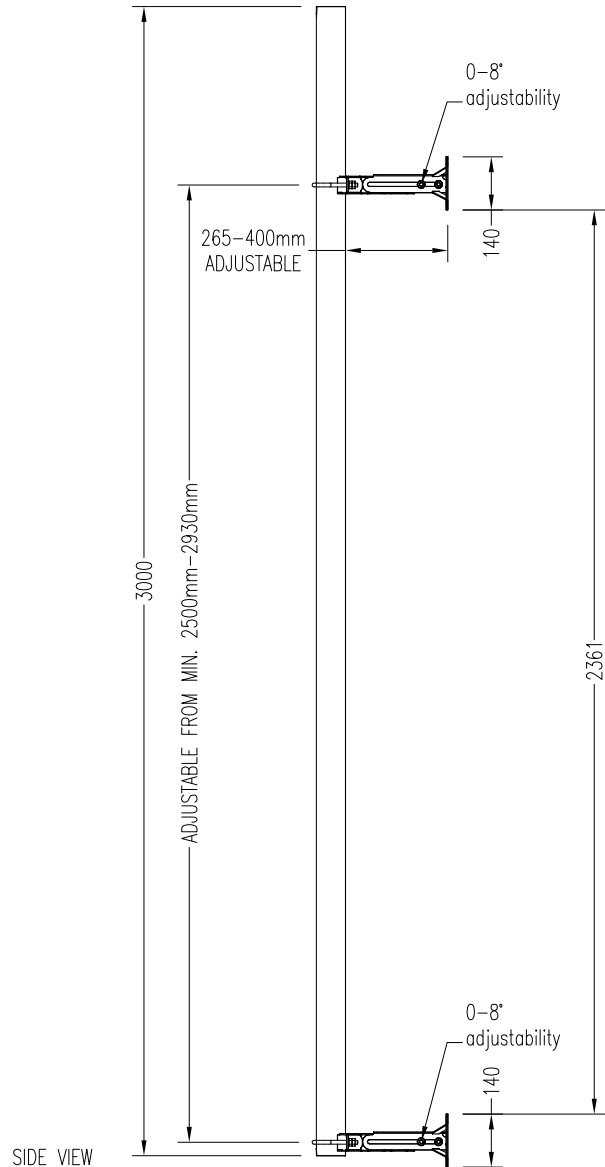

Graffo Innovative wireless infrastructure solutions

Tel: +27 (0)21 905-0010

Fax: +27 (0)21 905-0020

Web: www.graffo.co.za

Height adjustable wall to pole
3m Ø76 bracket with
265mm - 400mm stand-off
adjustability
Part no. : GR112-254-00-00B